



VH Series Single Shaft Shredder

Tel +44-1453-768980 • Fax +44-1453-768990 • www.cumberlandeurope.com • Bulletin: CG7-520E • Effective: November 11, 2008 • Supersedes: New

VH Series Horizontal Feed Rotary Profile Grinder

Application:

The VH Series Rotary Grinder is designed especially for size reduction of vinyl siding, PVC fencing, plastic extrusion profiles, and other scrap materials.

Benefits:

- Horizontal vibratory feed conveyor allows full length profiles, pipe, siding, and composite lumber to be ingested safely at a low infeed height.
Aggressive "clamp on" feedroll design positively holds the feedstock and forces the material into the cutter head.
2 or 4 blade "cutting insert" style rotors are ideal for producing high quality chips when processing profiles, paper, and cardboard.
Standard staggered rotor with reversible cutters for processing trim scraps, baled or loose film, synthetic fiber, wood processing scrap, medical waste, cardboard, paper, and carpet.

Specifications:

Table with 7 columns (Model, VH-14, VH-18, VH-22, VH-25, VH-34, VH-50) and 13 rows detailing specifications like Infeed opening, Rotor diameter, Number of cutters, Rotor speed, Drive motor, Machine weight, Voltage, Infeed conveyor, Feed rollers, and Throughput.

Standard Features:

- Low speed/high torque design
Easy accessibility
Equity "buyback" guarantee
4-way, indexable cutting inserts
Lifetime limited warranty on cutting rotor
Oversized drivetrain
Powerbelt rotor drive
Heavy, spherical roller bearings
High output "torsion point" cutting rotor
Severe duty construction
Built-in pneumatic discharge port
Stress-free frame, robotically welded

— See Page 2 For VH Series Drawings —



Cumberland VH Series Drawing

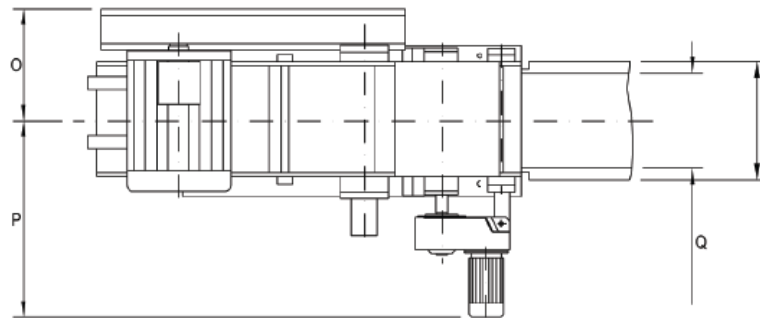
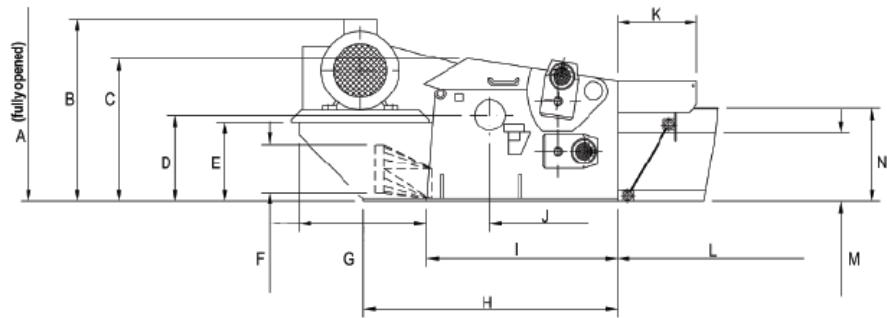

Model	A	B	C	D	E	F	G	H	I
VH-14	1055 mm	930 mm	660 mm	525 mm	342 mm	200 mm	625 mm	1150 mm	1000 mm
VH-18	1300 mm	1250 mm	900 mm	542 mm	500 mm	300 mm	800 mm	1600 mm	1200 mm
VH-22									
VH-25									
VH-34	1640 mm	1250 mm	1110 mm	740 mm	520 mm	N/A	830 mm	1500 mm	N/A
VH-50									

Model	J	K	L	M	N	O	P	Q	R
VH-14	415 mm	N/A	5000 mm	400 mm	560 mm	460 mm	660 mm	325 mm	433 mm
VH-18	397 mm	500 mm		430 mm	590 mm	530 mm	928 mm	450 mm	558 mm
VH-22						730 mm	1128 mm	850 mm	958 mm
VH-25			630 mm			1028 mm	650 mm	758 mm	
VH-34	552 mm	N/A	2000 mm	480 mm	670 mm	730 mm	1128 mm	850 mm	958 mm
VH-50						N/A	N/A	N/A	N/A