



U Series Granulators

Application:

The U Series Thermoforming granulators offer a wide range of capabilities and are ideal for under-the-press or in-front-of-the press applications. Three models provide various throat sizes—305x1117 mm, 305x1422 mm, and 305x1880 mm. Models feature powers from 15 kW to 37.3 kW and throughput capacities of 815 to 1360 kg/hr. Reversible screens are available in various sizes, and the complete regrind evacuation is achieved with a 203 mm blower system. The castered base is portable and low profile, which allows for under-the-press positioning.

Benefits:

- The two pivoting doors offer complete access into the bottom of the cutting chamber (screen cradle and screen). The larger 305 mm cutting circle and open screen area allow maximum throughput.
- Two swing open doors allow easy access to the screen cradles and screen.
- The 3-blade open rotor with Twinshear cutting geometry offers quieter, cooler operation and is ideal for polypropylene.
- Pneumatic upper hopper opening allows for easy access. Rotor and bed knives are easily accessed by tilting open the upper chamber.

Specifications (Consult Factory for Special Options):

Model	44U	56U	74U
Throat size, mm	305x1117	305x1422	305x1880
Cutting circle diameter, mm	305		
Feed height, mm	759		
Throughput, kg/hr	817	999	1362
Working Envelope, LxW, mm	2311x1854	2616x1854	3073x1854
Weight, kg	1815	2404	3629
Motor (rotor drive)	15 kW to 37.3 kW		
Motor (feedrole drive)	2.2 kW AC		
Controls	240/400v: 115V P/B (standard); 208/575v: 115v P/B (optional)		
Rotor	3-knife open Twinshear (standard); 5-knife open Twinshear (optional)		

Standard Features:

- 3-knife "open" Twinshear rotor; optional 5-blade open rotors available.
- Bolted and doweled construction.
- Pivoting screen cradle.
- 2 bed knives—reversible D2
- Rotor knives hi-angle
- Feed roll motor (2.2 kW AC)
- Oversized 178 mm diameter Steel Knurled Feed Rolls; optional paddle rolls are available.
- 305 mm cutting circle
- Low profile caster base
- 203 mm pneumatic discharge
- IP-55 controls
- 1 year warranty on parts and labor

— See Page 2 For C Series Drawings —



Cumberland U Series Granulators

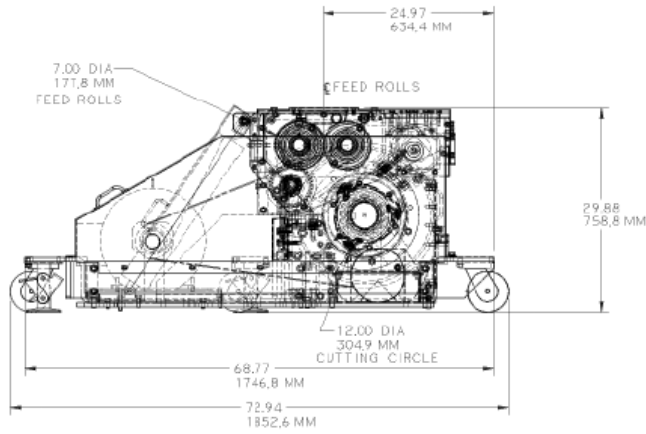
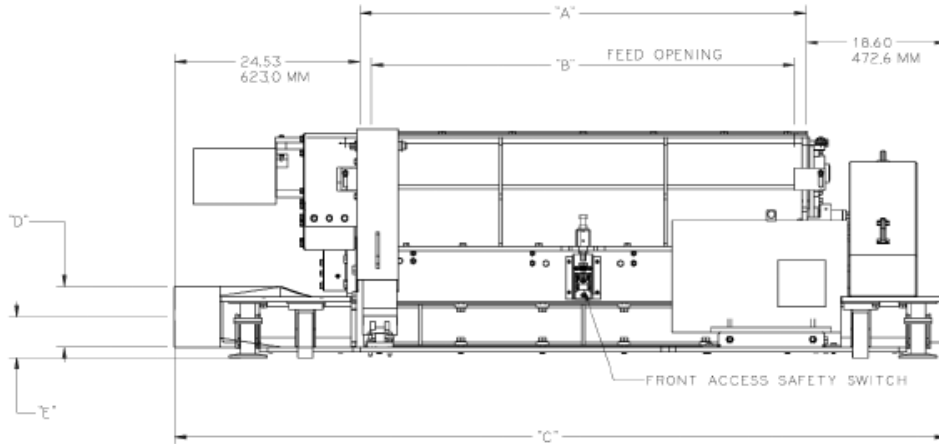

Dimensions

Model	A	B	C	D	E
44U	1194 mm	1118 mm	2311 mm	203 mm diameter	137 mm
56U	1499 mm	1422 mm	2616 mm		
74U	1955 mm	1880 mm	3074 mm	254 mm diameter	163 mm