



Technical Specification

T Series Granulators



Tel +44 (0) 1453-768980 • Fax +44 (0) 1453-768990 • www.cumberlandeurope.com • Bulletin: CG5-505E • Effective: November 10, 2008 • Supersedes: New

T Series Granulators

Application:

The T Series Granulators are compact granulators for inline processing of thermoformed scrap, including formed parts in the web with optional paddle rolls. The T Series Granulators are ideal for skeletal scrap with and without formed parts, expanded polystyrene, high impact polystyrene, HDPE, ABS, PET, and CPET. They can be positioned under or in front of the trim process.

Features:

Model	Throat Size	Cutting Circle Diameter	Throughput	Approximate Weight
36T	203 x 914 mm	200 mm	363-545 kg.	1181 kg.
56T	203 x 1422 mm	200 mm	454-681 kg.	1305 kg.

Benefits:

- Infeed design enables the processing of flat thermoforming skeleton and/or formed parts.
- Infeed assembly pivots open via gas springs for fast efficient access.
- Cutting chamber is machined and bolted for additional ease of cleaning.
- The screen and cradle's pivoting drop down design allows fast, convenient removal.
- Cumberland-manufactured knives are HCHC (D-2) steel, specially heat treated with our proprietary process for exceptionally long life, so knife maintenance and replacement costs are minimized.
- Hinged hopper tilts out of the way for unobstructed access.
- Screen is reversible for long life.
- Solid steel cutting chamber and bed knife blocks, doweled and bolted end plates for maximum strength. Castings are not used.
- Benefits are low noise, large positive bites, rapid ingestion and smooth, slicing action.

Specifications:

	Standard	Standard Options
Infeed	Feed Rolls – Poly smooth	Paddle Rolls Horizontal infeed hopper
Cutting Chamber	2-Bed knives, drop down cradle	
Rotor	3-knife Chevron (30T and 56T) Open 3-knife slant cut, scooped (36T)	
Rotor Knives	HCHC, keen edge	
Bed Knives	HCHC, 2-edge (reversible)	
Screen	8 mm, 2-piece reversible (30T and 56T) 8 mm, 1-piece reversible (36T)	6 mm, 10 mm, and larger
Base	Low profile caster	
Discharge	152 mm Airveyor	
Motor	3.7 kW (30T), 5.6 kW (36T and 56T) TEFC, 1800 rpm, 240/400v @ 50Hz	5.6 kW, 7.5 kW (30T) 7.5 kW, 11 kW, 15 kW (36T and 56T)
Feed Roll Motor	.56 kW, AC inverter	.75 kW, AC inverter
Drive Parts	V-belt	
Electrical Components	Start/Stop push buttons and safety interlocks	
Controls	240 or 400 volt, 115 volt, IP-55	
Labels	Safety/caution/operation	French/Spanish
Accessories		#6 Blower, 3.7 kW, Machine or Floor Mounted, #8 Separator, #8 Stand, Machine Sound Enclosure

— See Page 2 For T Series Drawings —



Cumberland T Series Granulators

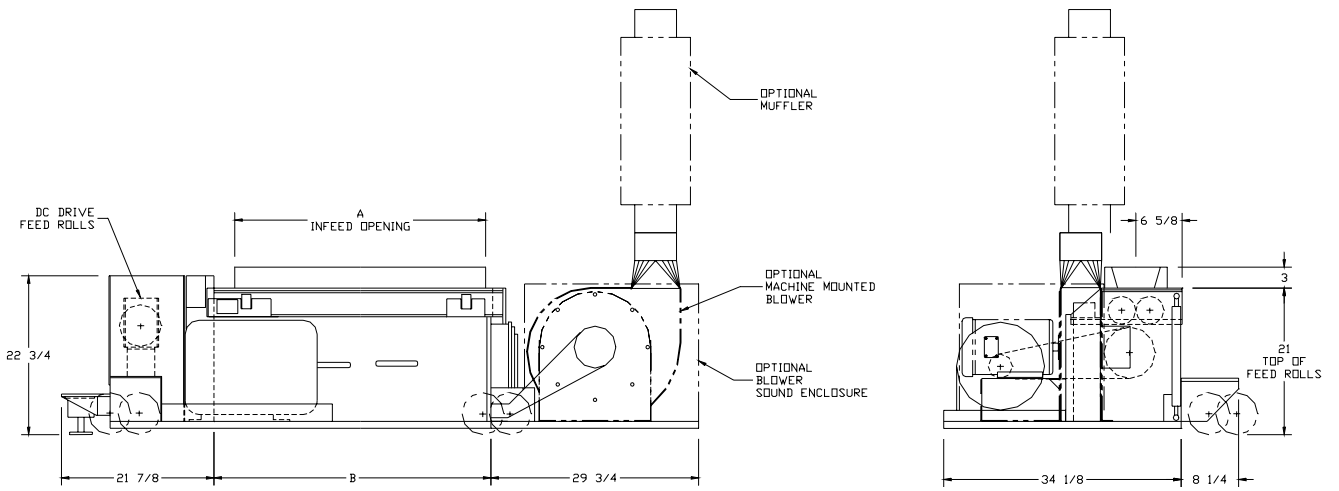
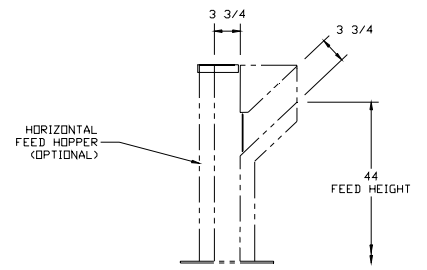

Dimensions

Model	A	B
36T	914 mm	1010 mm
56T	1422 mm	1518 mm