



CXS Series Single Shaft Shredder

Tel +44-1453-768980 • Fax +44-1453-768990 • www.cumberlandeurope.com • Bulletin: CG7-540E • Effective: November 12, 2008 • Supersedes: New

CXS Series Single Shaft Shredder

Application:

The CXS Series shredder is designed for processing plastic waste for reclamation and recycling large extruder purgings, reject parts, trim scraps, baled or loose film, synthetic fiber, wood processing scrap, medical waste, cardboard, paper, and carpet.

Standard Features & Benefits:

- Sturdy ram construction that incorporates heavy-duty guide bearings and universal couplings for reliable operation.
- Serrated ram plates for easy processing of large awkward pieces.
- Heavy-duty outboard bearings minimize risk of contamination.
- Rotors equipped with square cutter blocks for efficient cutting of material while reducing heat build-up and degradation.
- Large 750 mm diameter rotor for positive ingestion.
- Abrasion-resistant rotor standard for long life.
- Bolted-in cutter seat for easy removal and maintenance.
- Easy knife and screen access.
- Specialized rotors with hardened alloys for demanding applications.
- Standard feed hopper design allows feeding via tipping skip as well as manual feeding of large bulky parts.
- Two-speed ram hydraulics.

Optional Features:

- Hydraulic screen cradle
- Rotor cooling
- PLC with display
- Chamber-wear protection
- Infeed and discharge conveyors
- Easily configured with 2nd stage granulation



Large diameter rotor with "Swing Style" ram and serrated front surface.



Two-stage hydraulics with air cooler for long life.

— See Page 2 For CXS Series Drawings —



Specifications:

Standard Description	CXS-1500	CXS-2000	CXS-3000
Large capacity hopper feed opening, mm	2540 x 1600	2540 x 2007	2540 x 2820
Usable open area of cutting chamber, mm	1500 x 1473	1500 x 1905	1500 x 2692
Standard motor in kW	2 x 75	2 x 75	2 x 110
Number of rotor knives	76	96	136
Number of bed blades	4	5	7
Rotor diameter, mm	750		
Rotor speed in rpm	54		
Motor of hydraulic device, kW	11		
Available screen sizes, mm	25 – 102		
Mounted knife holders	Included		
Hopper for manual/conveyor feeding	Included		
Hydraulic feeding ram	Included		
Two speed turbo-hydraulic	Included		
Ram comb plate	Included		
Control panel SPS	Included		
Ampere-meter in control cabinet	Included		

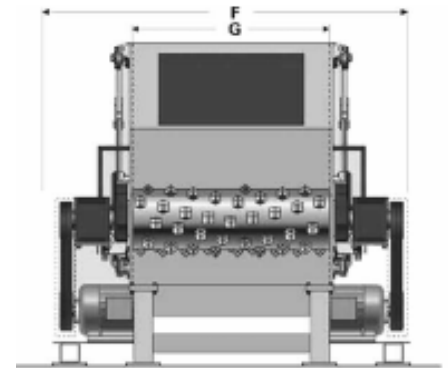
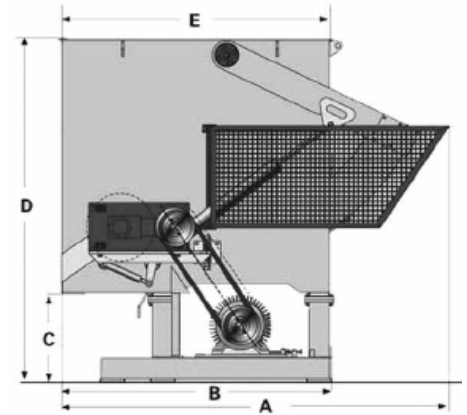

Dimensions, mm	CXS-1500	CXS-2000	CXS-3000
A	3607		
B	2590		
C	864		
D	3353		
E	2540		
F	3200	3837	4902
G	1625	2032	2820