



Technical Specification



B Series Central Granulators

Tel +44-1453-768980 • Fax +44-1453-768990 • www.cumberlandeurope.com • Bulletin: CG6-530E • Effective: November 21, 2008 • Supersedes: New

B Series Central Granulators

Application:

The B Series Granulators are heavy-duty, high capacity granulators for central reclamation. B Series granulators are ideal for pipe, purgings, x-ray film, post-consumer baled bottles, film, and fibers. B Series Granulators feature High Shear Rotors,

Features:

Model	Throat Size	Cutting Circle Diameter	Throughput	Approximate Weight
24B	381 x 610 mm	356 mm	454 kg/hr	2722 kg
28B	457 x 711 mm	406 mm	817 kg/hr	3175 kg
37B	457 x 940 mm		1135 kg/hr	4990 kg
50B	510 x 1270 mm	457 mm	1589 kg/hr	6804 kg
62B	510 x 1575 mm		2043 kg/hr	9979 kg
72B	510 x 1830 mm		2270 kg/hr	11793 kg

Benefits:

- Heavy-duty construction allows granulator to handle heavier loads.
- Internal surfaces machined for ease of clean-out and material flow.
- Optimum cutting efficiency, with low power consumption.
- The rotor knives are bolted to the rotor with high-strength alloy steel bolts.
- Outboard mounted, heavy-duty, spherical roller bearings prevent bearing contamination.
- Heavy duty overall construction: main frame, rotor, downstroke shield, steel plate bedknife blocks & belts. Larger, spherical roller bearings and heavy-duty flywheel sheave.
- End removable screen.

B Series Specifications:

	Standard	Standard Options
Infeed	Conveyor feed	Tray and sheet feed, Tray and feed rolls, Pipe feed
Cutting Chamber	2-bed knife	Hard facing, water cooling, air purge bearings
Rotor	Open 3-knife high-shear	5-knife high-shear, 3-knife steep angle, 5-knife S/A, 7-knife S/A (62B and 72B only)
Rotor Knives	(3) HCHC	(5) HCHC, Steep angle, 55°
Bed Knives	(2) HCHC	Raised D/S
Screen	10 mm N.H.T.	6 mm and larger, H.T.
Drive Parts	V-belt	
Electrical Components	Start/Stop push buttons and safety interlocks	
Controls	Customer supplied	240, 400 volt, IP-55
Labels	Safety/caution/operation labels	
Accessories		Blower, Cyclone, Separator, Conveyor

Model	Base		Discharge		Motor	
	Standard	Std. Option	Standard	Std. Option	Standard	Std. Option
37B	940 mm Step	559 mm Low Airveyor	205 mm Airveyor Chute	Gaylord, 203-305 mm Airveyor	75 kW	75-112 kW
50B			254 mm Airveyor Chute		112 kW	75-150 kW
62B		787 mm Low Airveyor	305 mm Airveyor Chute	Gaylord, 254-356 mm Airveyor	150 kW	75-250HP
72B					150 kW	75-186 kW

— See Page 2 For B Series Drawings —



Cumberland B Series Central Granulators

37 B:

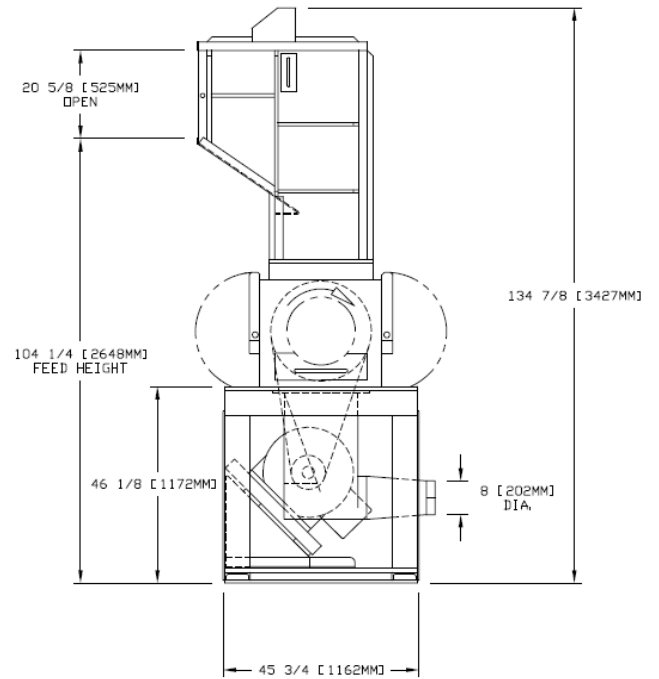
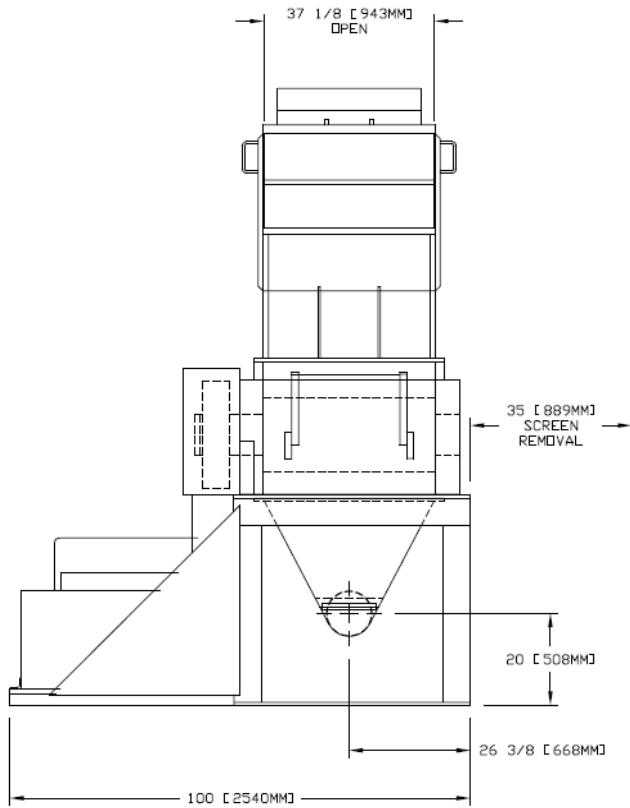

50 B:

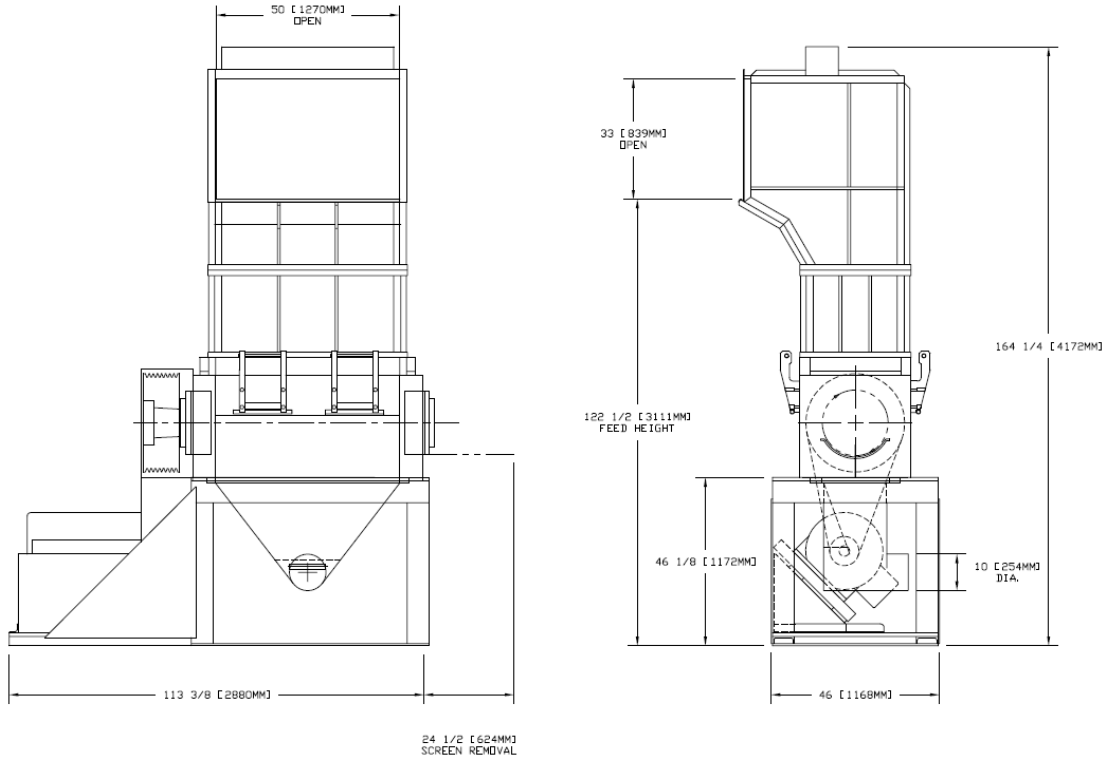

62 B:

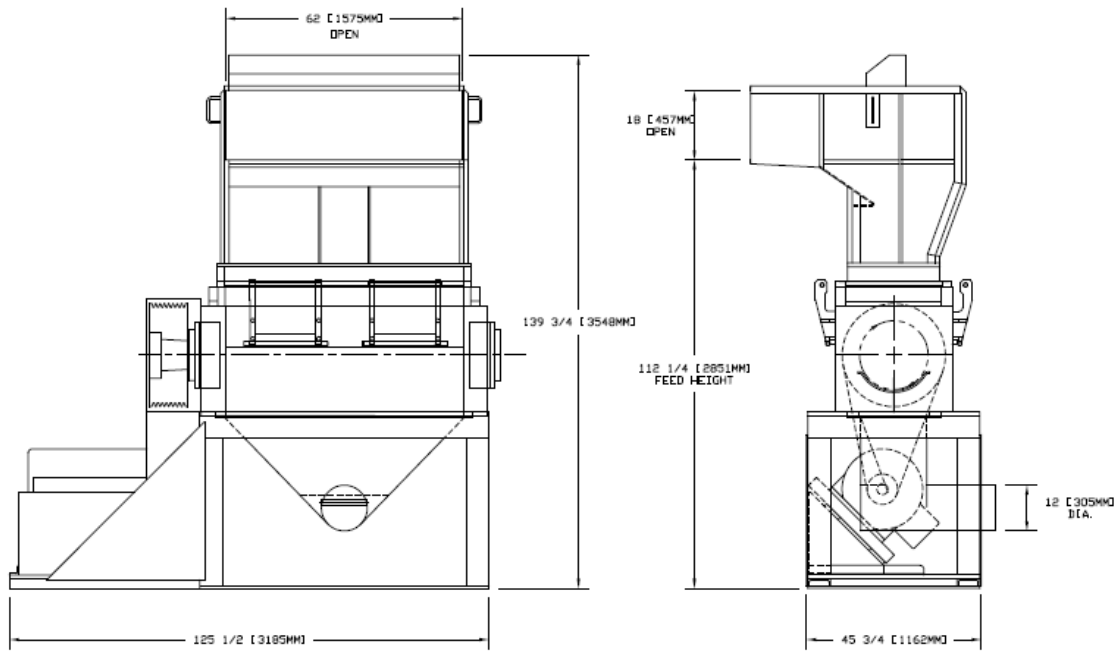

72B:

